

Grid:
 ≥ 2,54 mm
 ≥ 100 Mil

Installation Height: 10,0 mm (.394)
Switching Path: 1,5 mm (.059)

Mounting and Functional Dimensions

SKS-215

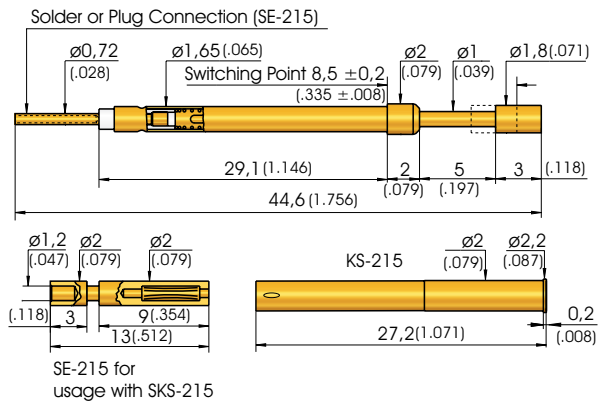

SKS-215 ... E

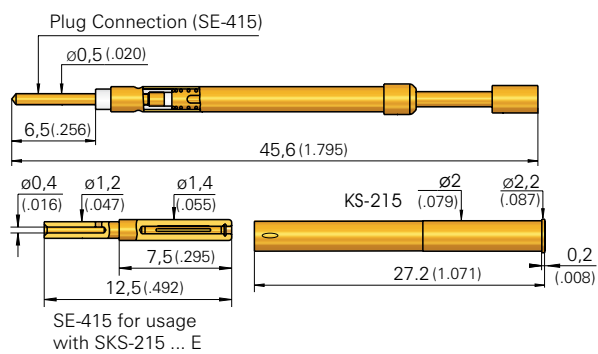

Quick-exchange System with SKS-215 ... E

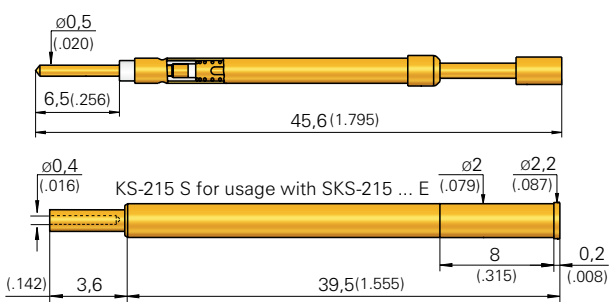

Mechanical Data

Switching Path: 1,5 mm (.059) ± 0,2 (.008)
Maximum Stroke: 5,0 mm (.197)
Spring Force: 0,8 / 1,5 / 3,0 N
Spring Force at Switch.Point: 0,23N (0.8oz); 0,45 N (1.6oz); 0,9 N (3.2oz)
Spring Force at 80% Stroke: 0,8 N (2.9oz); 1,5 N (5.4oz); 3,0 N (10.8oz)

Materials

Plunger: BeCu, gold- or nickel-plated (or gold-plated with Insulator Cap)
Barrel: Brass, gold-plated
Spring: Steel, gold-plated
Receptacle: Brass, gold-plated
Contact Terminal: Brass, gold-plated

Electrical Data

Current Rating: 3 A
 (see page 77)

Mounting Hole Size

with Receptacle: s. KS-112 Page 50
without Receptacle: ø 1,65 mm (.0650)

Available Tip Styles

Material	Tip Style	Plating	Further Versions	
			ø	ø (inch)
0 02		A		
3 02		A	1,00	(.039)
3 03		A		
NEW 3 05		A	0,80	(.031)
3 05		A		
3 06		N		
NEW 3 19		A		

Collar Height and Installation Height

The Installation Height of the Tip (Dimension without KS) is determined by the Collar Height.

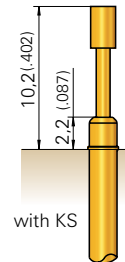

Collar Height	Installation Height (without Receptacle)
02	10,0 mm (.394)

Application Areas:

- combined component test with presence check
- active switching element

Warning:

Do not solder the cable to the crimp points of the Receptacle.

The Receptacle KS-215 S enables easy changing of the Switching Probe without removing the wiring connection. This Receptacle can only be used with SKS-215 ... E.

Note:

The special Tool "SW/ZW GKS-112" must be used to install the Switching Probe (see Page 118).

Note:

Screw-in Version see SKS-215 M on Page 148.

Ordering Example

Series	Tip Material	Tip Style	Tip Diameter (1/100 mm)	Plating	Spring Force at 80% Stroke (dN)	Collar Height (mm)	Type (alternative E)
SKS	0 = Delrin 3 = BeCu	215	302	A = Gold N = Nickel	30	02	

Test Probe:

SKS 215 302 180 A 30 02

Receptacle:

KS-215 KS-215 S

Lamellar Plug:

SE-215